

# Static Grizzly Feeders

A PRODUCT OF THE MATERIAL HANDLING EQUIPMENT FAMILY

Our heavy duty static grizzly feeders allow customers to size materials through a slotted set of grizzly bars with adjustable spacing. This reliable and durable equipment can effectively prepare and screen your materials.

The static grizzly feeders are designed to be fed with a wheel loader or excavator with the oversize sliding to the front of the unit and the finer material passing through the grizzly to be picked up from the back.

## Screen materials

- Rock
- Sand and gravel
- Coal
- Granular soils
- Other non-compacting bulk materials



## Benefits

- Rugged design
- Wide target
- Adjustable opening
- Well-suited for materials less than 24"



Custom Solutions to Unique Challenges

## STATIC GRIZZLY FEEDERS

### Standard Specifications

- 12' or 14' wide heavy duty static grizzly feeder
- Structural frame of 4" x 4" square tubing with 0.25" steel plate on lower area
- Upper and lower grizzly bar supports are 3" x 3" x 0.25" with a 3" x 3" x 0.375" angle
- Center grizzly bar support is a heavy duty 4" x 8" square tubing
- Adjustable bar spacing for 2"-6" on 1" increments
- Bar materials is a 3" x 3" x 0.375" square tubing rotated to form a diamond cross section
- Standard bar spacing is 6"
- Complete plant is primed and painted Peerless Tan

### Optional Equipment

- Additional heavy duty bars for closer spacing requirements

Contact us at (913) 233-3854 or [sales@peerlessemc.com](mailto:sales@peerlessemc.com) to get started.

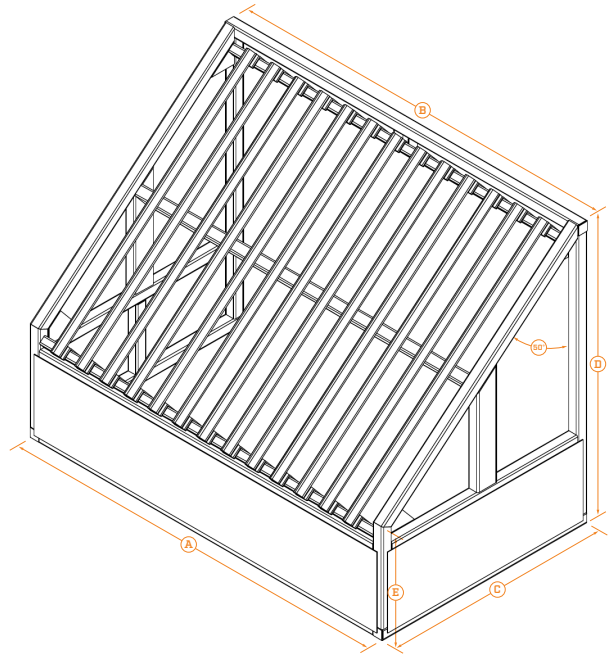

Static Grizzly Feeders		
Model	12' Heavy Duty	14' Heavy Duty
A	12'-1.5"	14'-7.5"
B	12'-1"	14'-7"
C	7'-3.4375"	7'-3.4375"
D	9'	9'
E	3'-4.625"	3'-4.625"
Weight	4,335 lbs.	5,070 lbs.

See *Material Handling Equipment: Feed Hoppers brochure* for more information about this product family.



### ABOUT PEERLESS

Peerless solves unique challenges for our customers by supplying material processing and handling equipment—including quarry, asphalt, aggregate, frac sand, and mining. Peerless designs a variety of stock and custom products, ensuring consistent delivery of engineered solutions. Experienced and innovative, the Peerless team is focused on quality and listening to customers' specific needs.

© 2020 Peerless Engineering and Manufacturing Co.

[www.peerlessemc.com](http://www.peerlessemc.com)

Kansas City office (913) 233-3854  
Request a quote (816) 381-0635  
[sales@peerlessemc.com](mailto:sales@peerlessemc.com)

 Peerless Engineering and Manufacturing Company