

824 TD Portable Superbase Plants

A PRODUCT OF THE SUPERBASE SCREEN PLANTS FAMILY

Our strong and durable Superbase screen plants support the most difficult applications. With the 824 TD Portable, customers can effectively screen their desired sizes of product.

Standard specifications include a heavy duty I-beam portable chassis with landing jacks and four cribbing points, a triple shaft screen with electric drive, an underscreen hopper with angle bracing and rear discharge product conveyor, two side-discharge product conveyors that fold for travel, a discharge chute with sectionalized flop gates, and fold down walkways with ladder access. Optional equipment includes a roll-away discharge chute, run-on jacks, and a motor control panel.

Screen materials

- Rock
- Sand and gravel
- Asphalt millings
- Certain soils
- Other granular materials

Benefits

- Rugged, portable design
- Blending capability allows for screened decks to be blended
- Optional equipment available to meet your specific needs

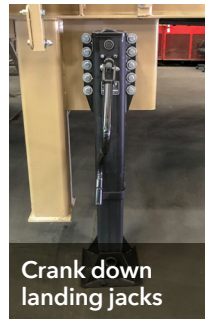

Custom Solutions to Unique Challenges

824 TD PORTABLE SUPERBASE SCREEN PLANTS

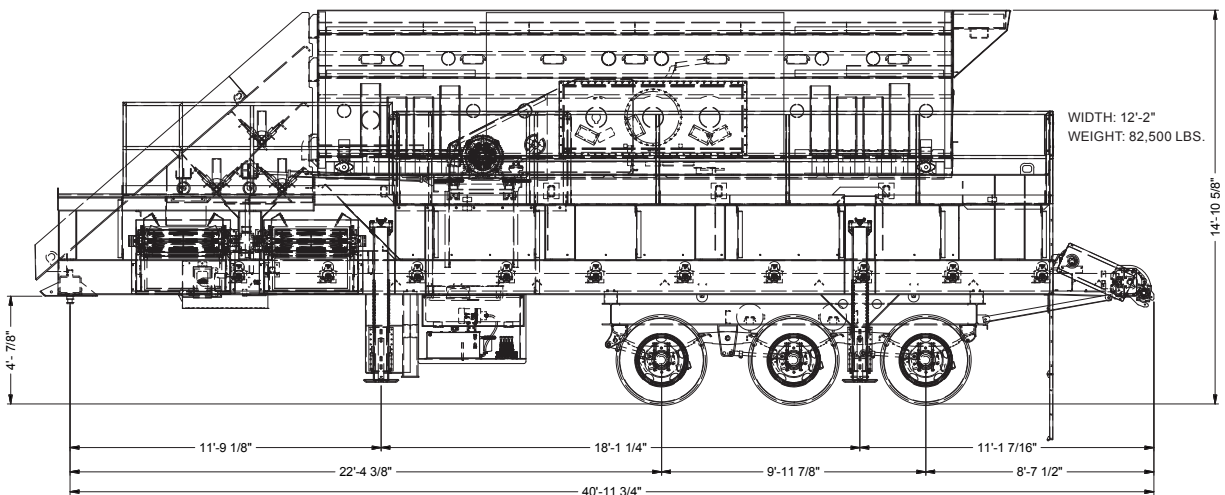

Standard Specifications

- Heavy duty I-beam portable construction and Tandem axle suspension
- Two stabilizing jacks and four cribbing supports
- 75HP standard TEFC electric motor for screen drive
- 36" walkways accessible around three sides
- Underscreen hopper made using 1/4" thick plate with angle-type bracing
- Heavy duty discharge chute made from 1/4" thick plate, lined with AR plate in heavy wear areas
- Discharge chute includes top deck over chute, middle and bottom deck chute with three rows of flop gates, each with four flop gate sections
- Approximately 30'-0" long underscreen conveyor with 60" belt width, powered by 10HP electric motor
- Conveyor includes 5" dia CEMA-C troughing and return idlers

- Belting is 2-ply 3/16" x 1/16" with vulcanized splice and Martin belt cleaner
- Two product conveyors, 30" x 14'-0" long powered by 5HP TEFC electric motor with Dodge Quantis reducer
- Complete plant is primed and painted Peerless Tan

Optional Equipment

- 100HP electric motor with urethane decks
- Roll-away chutes and extended walkways
- Motor controls and wiring
- Your choice of standard wire screen cloth
- Flop gate row for top deck chute
- Hydraulic run-on jacks

Contact us at (913) 233-3854 or sales@peerlessemc.com to get started.



ABOUT PEERLESS

Peerless solves unique challenges for our customers by supplying material processing and handling equipment—including quarry, asphalt, aggregate, frac sand, and mining. Peerless designs a variety of stock and custom products, ensuring consistent delivery of engineered solutions. Experienced and innovative, the Peerless team is focused on quality and listening to customers' specific needs.

© 2019 Peerless Engineering and Manufacturing Co.

www.peerlessemc.com

Kansas City office (913) 233-3854
Request a quote (816) 381-0635
sales@peerlessemc.com

Peerless Engineering and Manufacturing Company