

Single Deck Scalp Screens

A PRODUCT OF THE VIBRATING INCLINE SCREENS FAMILY

These highly efficient screens allow our customers to scalp off unwanted material from their primary product. Our vibrating incline screens offer reliable, high-energy, and high-capacity solutions.

The Peerless single deck scalp screens separate material consistently and accurately. These models use a high-speed eccentric set of counter weights, mounted through the center of the side plates, which provides a 3/16" – 1/4" stroke for a "buzzing" style vibration.

Standard screen calculations should be considered when choosing any screen for your application.

Screen materials

- Sand
- Gravel
- Recycled asphalt pavement
- Dirt
- Crushed stone

Available Deck Sizes

Single	Double	Triple
36 x 6, 8	36 x 6, 8	36 x 6, 8
48 x 8, 10, 12	48 x 8, 10, 12	48 x 8, 10
60 x 10, 12	60 x 10, 12	

Double and Triple Deck Scalp Screens specifications available separately.

See *Vibrating Incline Screens brochure*, pages 3 and 4, for screen sizing.

Benefits

- Built for durability with double roller bearings
- Optimal control with easy stroke and speed adjustment
- Quality performance and wide horsepower range
- Clean separation of materials, including sand, gravel, recycled asphalt pavement, dirt, and crushed stone



Custom Solutions to Unique Challenges

SINGLE DECK SCALP SCREENS

Standard Specifications

- Electric motors ranging from 3HP to 15HP
- Motor mount and v-belt drive with drive guard
- Double roller bearings
- Heavy duty coil springs
- Heat treated and stress relieved screen box
- Cast iron eccentric flywheels with removable weights for stroke adjustment
- Your choice of standard side tension screen cloth
- Painted with primer and finish coat of Peerless Tan Urethane

Optional Equipment

- Optional stand with an underscreen hopper
- Optional discharge chute
- Optional motor control and wiring package

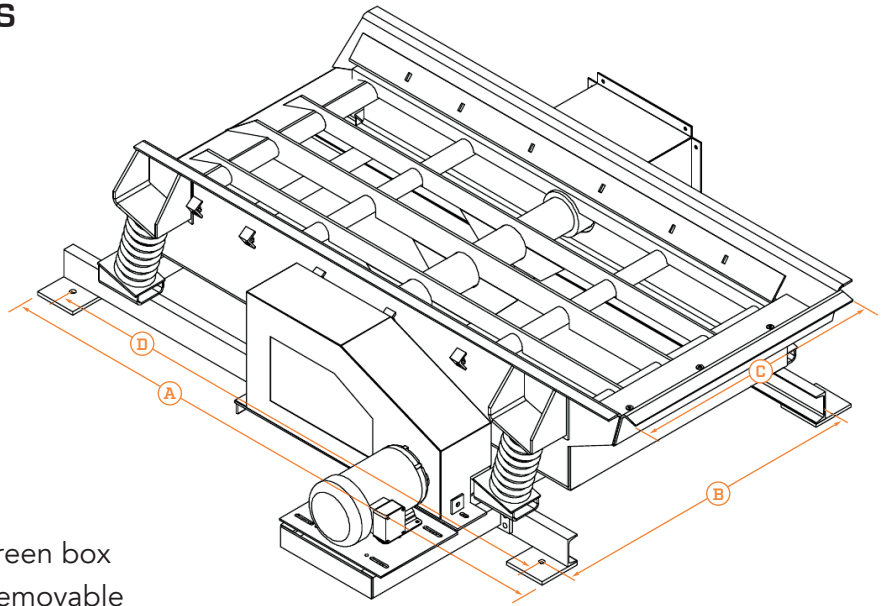

Single Deck Scalp Screens						
Model	SD366	SD368	SD488	SD4810	SD6010	SD6012
Dimensions	36" x 6'	36" x 8'	48" x 8'	48" x 10'	60" x 10'	60" x 12'
A	7'-2"	9'-2"	9'-2"	10'-10"	10'-10"	12'-10"
B	3'-10 ³ / ₄ "	3'-10 ³ / ₄ "	4'-10 ³ / ₄ "	4'-9 ⁷ / ₈ "	5'-9 ³ / ₄ "	5'-9 ³ / ₄ "
C	3'	3'	4'	4'	5'	5'
D	6'-8"	8'-8"	8'-8"	10'-4"	10'-4"	12'-4"
HP	3	3	5	7.5	10	10
Weight	895	1250	1620	1990	2200	2795

Contact us at (913) 233-3854 or sales@peerlessemc.com to get started.

See *Vibrating Incline Screens* brochure for more information about this product family.



ABOUT PEERLESS

Peerless solves unique challenges for our customers by supplying material processing and handling equipment—including quarry, asphalt, aggregate, frac sand, and mining. Peerless designs a variety of stock and custom products, ensuring consistent delivery of engineered solutions. Experienced and innovative, the Peerless team is focused on quality and listening to customers' specific needs.

© 2019 Peerless Engineering and Manufacturing Co.

www.peerlessemc.com

Kansas City Office (913) 233-3854
Request a quote (816) 381-0635
sales@peerlessemc.com

Peerless Engineering and Manufacturing Company